

348 Chatswood Road SHAILER PARK QLD

4 2 2

Enjoying an elevated position to capture the views, this exceptional residence has enjoyed a complete renovation and the results are nothing short of show-stopping!

This is a home with serious liveability credentials, offering a functional well-devised layout that caters perfectly to the modern family. On entry, prepare to be 'wowed' by the airy and open living zones, the quality fittings and chic finishes throughout the home.

Not a cent has been spared and not a thing left undone on both the interior and exterior of the home- a lucky new owner indeed who will reap the benefits and get straight on with simply enjoying life!

Multiple living & entertaining areas offer that much needed

[For full version visit the website](#)

Type : House
Price : \$ 807,700
Land Size : 1123 sqm
View : <https://www.markcoleman.com.au/6451937>



Mark Coleman Team
0434169033

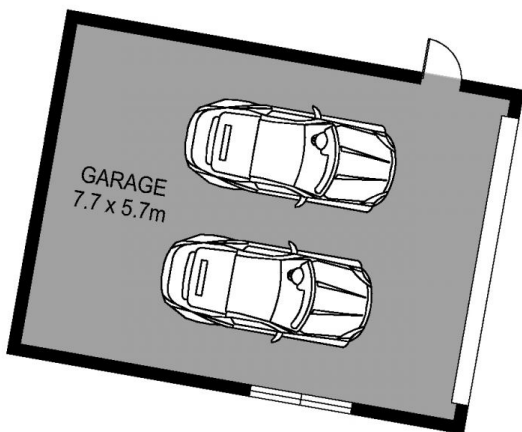
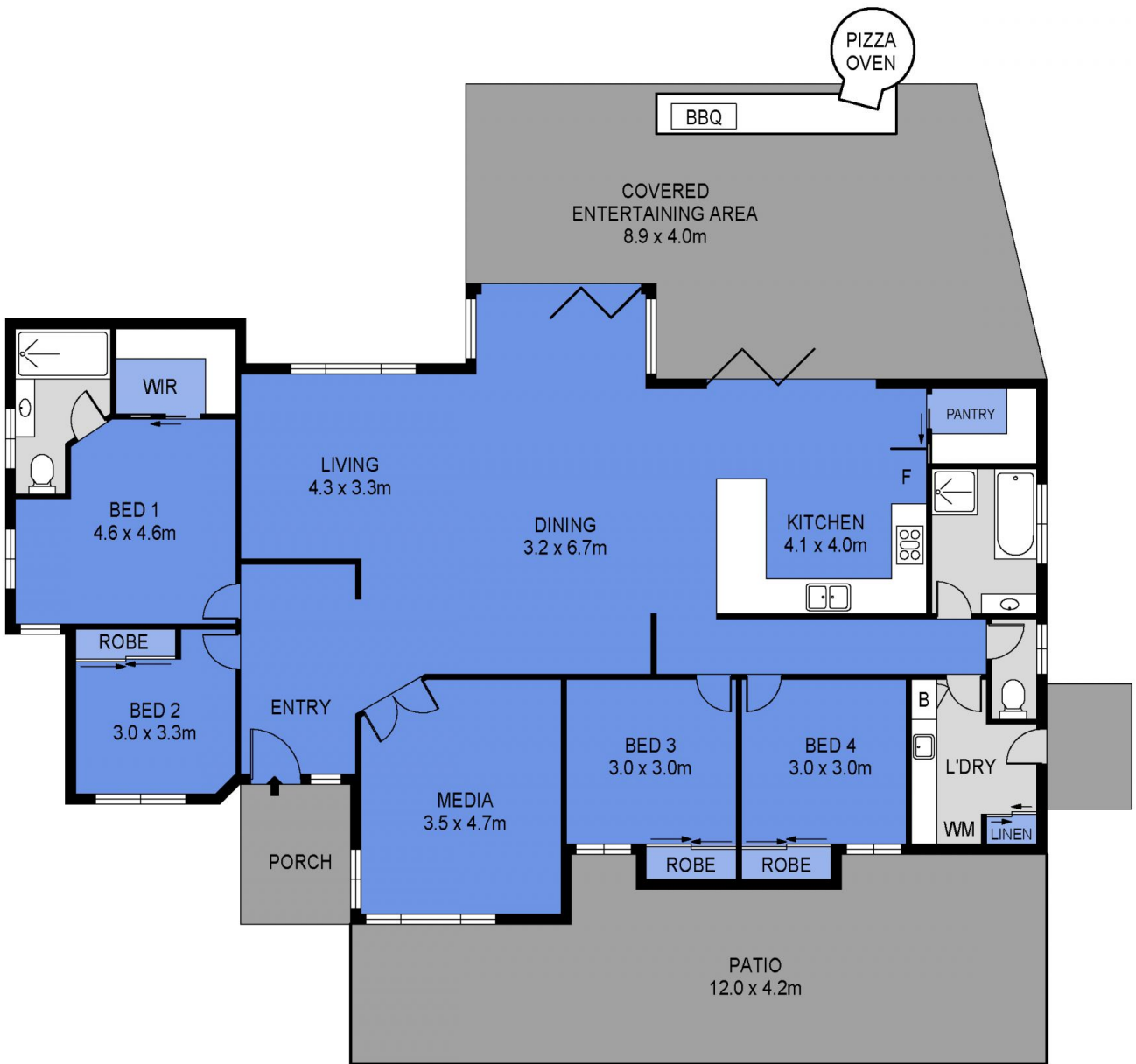

Scale in metres. Indicative only. Dimensions are approximate. All information contained herein is gathered from sources we believe to be reliable. However we cannot guarantee its accuracy and interested persons should rely on their own enquiries

INT : 194m²
 EXT : 112m²
 GARAGE : 44m²



348 Chatswood Road, Shailer Park